

Y-Bearing Take - Up Units With Grey Cast Iron Housings "T"

LYT 211 2F

Y-Bearing Take - Up Units With Grey Cast Iron Housings "T"

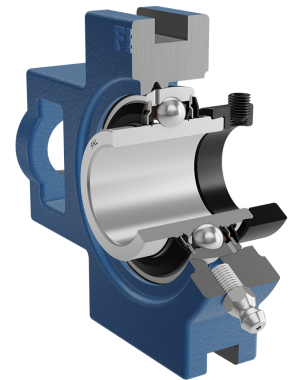
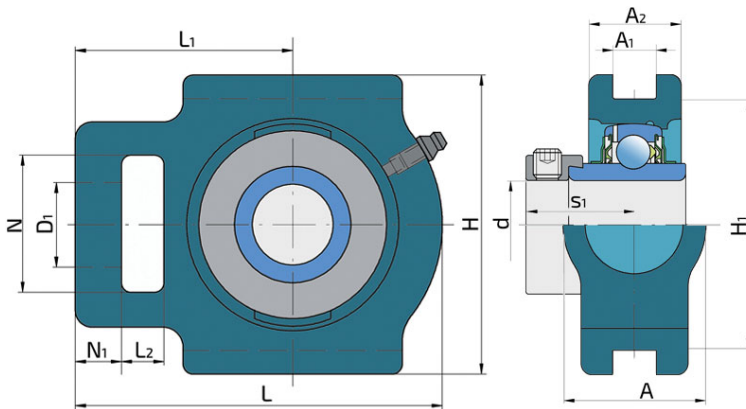

Technical Specification

d	Bore diameter	55 mm
D1	Hole diameter	35 mm
L	Overall length	171 mm
L1	Distance from the contact surface of housing to the bearing axis	106 mm
L2	Length of attachment slot	25 mm
A	Overall width	64 mm
A1	Width of location slot	27 mm
A2	Housing flange thickness	41 mm
H	Housing height	146 mm
H1	Distance between bottoms of location slot	130 mm
N	Height of attachment slot	64 mm
N1	Length attachment end	19 mm
s1	Distance from locking device side face to raceway centre	43.6 mm
kg	Mass	4.2 kg
Cdyn	Dynamic load rating	43.6 kN
Co	Static load rating	29 kN
Pu	Fatigue load limit	1.25 kN

Sealing

F SEAL / F SEAL (2F)

Dual sealing, protection cover placed on the inner ring protects against rough impurity particles and makes the labyrinth with the sheet part of the seal; then the sealing S type,

with the labyrinth between the sheet part and the rubber lip that conducts the contact sealing. The friction and speeds are the same as with S but has much better protection

against rough impurity particles. It is very good sealing system: the sheet part protects the seal from the soil, dust and

rough particles. At the same time makes the labyrinth with the rubber part. The rubber part provides the contact sealing that prevents the penetration of the finer impurities, water, moisture, steam etc. Suitable for heavier conditions due to better protection against foreign matters. It is used with the Y bearings (standard).

