

# Y-Bearing Flanged Units With Round Grey Cast Iron Housing "G"

## UYG 212 2S

Y-Bearing Flanged Units With Round Grey Cast Iron Housing "G"

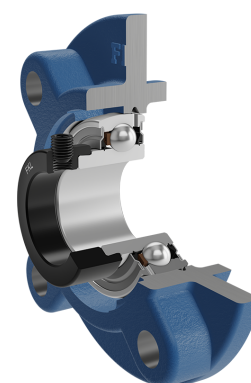
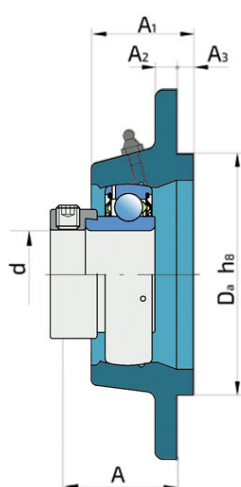
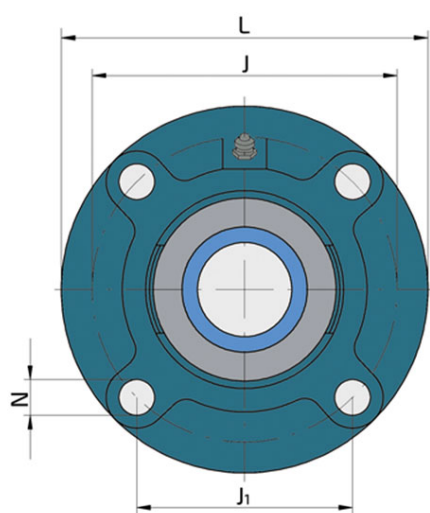

### Technical Specification

d	Bore diameter	60 mm
Da	Centering diameter	135 mm
L	Overall width	195 mm
A	Distance from the housing flange to the front of the inner ring of the bearing	57.3 mm
A1	Total housing width	48 mm
A2	Housing flange thickness	15 mm
A3	Centering diameter height	12 mm
J	Pitch circle diameter	160 mm
J1	Distance between the holes	113.1 mm
N	Diameter of attachment slot	19 mm
kg	Mass	4.59 kg
Cdyn	Dynamic load rating	52.7 kN
Co	Static load rating	36 kN
Pu	Fatigue load limit	1.53 kN

## Sealing

---

### S SEAL / S SEAL (2S)

Single lip seal with the labyrinth between the sheet part and the rubber lip which conducts the contact sealing. The friction and speeds are the same as with RS but provides much better protection against the rough impurity particles. This is very good sealing system: the sheet part protects the seal from the soil, dust and rough particles. At the same time makes the labyrinth with the rubber part. The rubber part provides contact sealing which prevents penetration of finer impurities, water, moisture, steam etc. Suitable for neutral conditions because of the presence of the foreign materials. It is used with the Y bearing (standard) and deep groove ball bearings.

