

Y-Bearing Flanged Units With Round Grey Cast Iron Housing "G"

UEG 210 2S

Y-Bearing Flanged Units With Round Grey Cast Iron Housing "G"

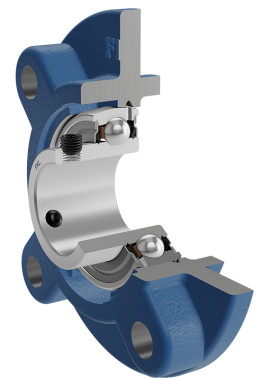
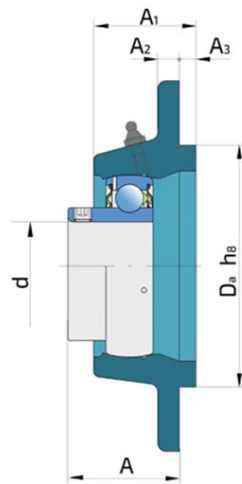
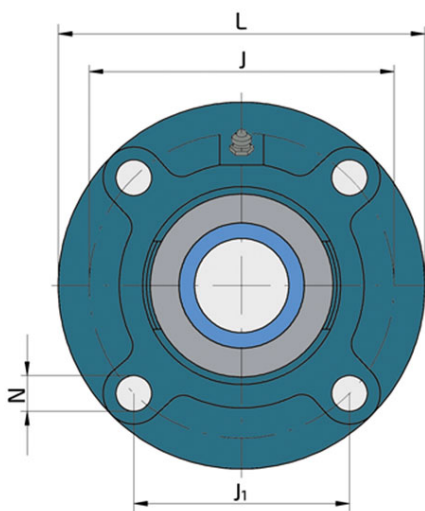

Technical Specification

d	Bore diameter	50 mm
Da	Centering diameter	110 mm
L	Overall width	165 mm
A	Distance from the housing flange to the front of the inner ring of the bearing	37.6 mm
A1	Total housing width	40 mm
A2	Housing flange thickness	14 mm
A3	Centering diameter height	12 mm
J	Pitch circle diameter	138 mm
J1	Distance between the holes	97.6 mm
N	Diameter of attachment slot	16 mm
kg	Mass	2.78 kg
Cdyn	Dynamic load rating	35.1 kN
Co	Static load rating	23.2 kN
Pu	Fatigue load limit	0.98 kN

Sealing

S SEAL / S SEAL (2S)

Single lip seal with the labyrinth between the sheet part and the rubber lip which conducts the contact sealing. The friction and speeds are the same as with RS but provides much better protection against the rough impurity particles. This is very good sealing system: the sheet part protects the seal from the soil, dust and rough particles. At the same time makes the labyrinth with the rubber part. The rubber part provides contact sealing which prevents penetration of finer impurities, water, moisture, steam etc. Suitable for neutral conditions because of the presence of the foreign materials. It is used with the Y bearing (standard) and deep groove ball bearings.

