

Y-Bearing Flanged Units With Round Grey Cast Iron Housing "G"

UYG 208 2S

Y-Bearing Flanged Units With Round Grey Cast Iron Housing "G"

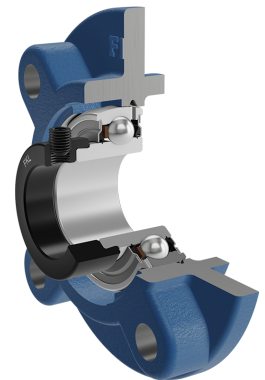
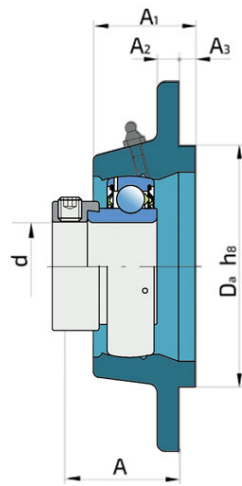
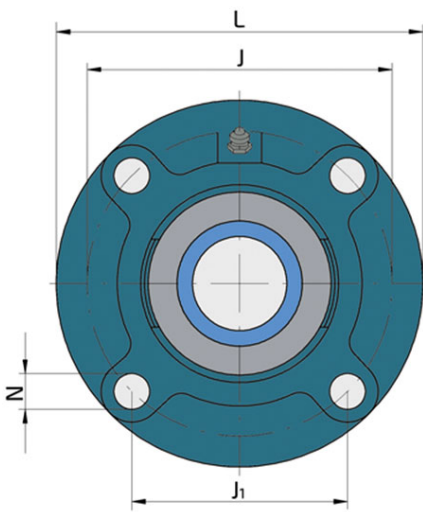

Technical Specification

d	Bore diameter	40 mm
Da	Centering diameter	100 mm
L	Overall width	145 mm
A	Distance from the housing flange to the front of the inner ring of the bearing	43.7 mm
A1	Total housing width	36 mm
A2	Housing flange thickness	9 mm
A3	Centering diameter height	10 mm
J	Pitch circle diameter	120 mm
J1	Distance between the holes	84.8 mm
N	Diameter of attachment slot	14 mm
kg	Mass	1.92 kg
Cdyn	Dynamic load rating	30.7 kN
Co	Static load rating	19 kN
Pu	Fatigue load limit	0.8 kN

Sealing

S SEAL / S SEAL (2S)

Single lip seal with the labyrinth between the sheet part and the rubber lip which conducts the contact sealing. The friction and speeds are the same as with RS but provides much better protection against the rough impurity particles. This is very good sealing system: the sheet part protects the seal from the soil, dust and rough particles. At the same time makes the labyrinth with the rubber part. The rubber part provides contact sealing which prevents penetration of finer impurities, water, moisture, steam etc. Suitable for neutral conditions because of the presence of the foreign materials. It is used with the Y bearing (standard) and deep groove ball bearings.

