

Y-Bearing Flanged Units With Round Grey Cast Iron Housing "G"

UEG 207 2S

Y-Bearing Flanged Units With Round Grey Cast Iron Housing "G"

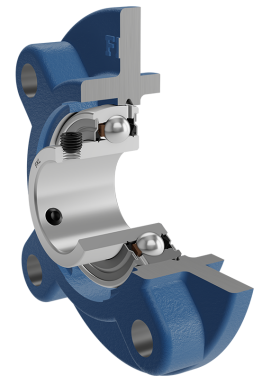
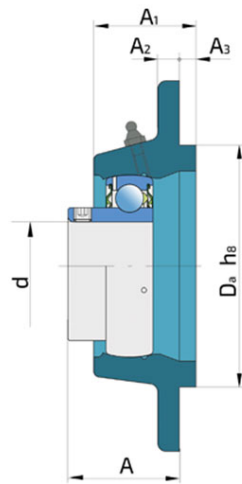
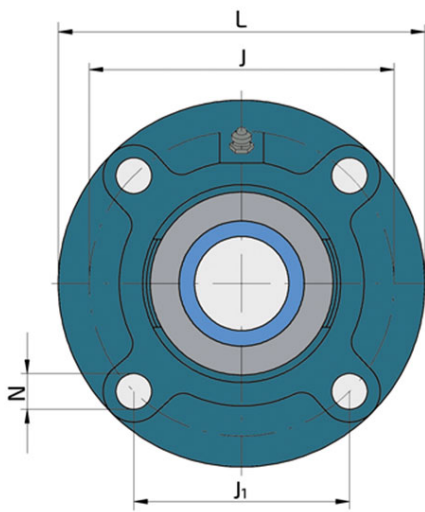

Technical Specification

d	Bore diameter	35 mm
Da	Centering diameter	90 mm
L	Overall width	135 mm
A	Distance from the housing flange to the front of the inner ring of the bearing	34.3 mm
A1	Total housing width	34 mm
A2	Housing flange thickness	9 mm
A3	Centering diameter height	8 mm
J	Pitch circle diameter	110 mm
J1	Distance between the holes	77.8 mm
N	Diameter of attachment slot	14 mm
kg	Mass	1.57 kg
Cdyn	Dynamic load rating	25.5 kN
Co	Static load rating	15.3 kN
Pu	Fatigue load limit	0.655 kN

Sealing

S SEAL / S SEAL (2S)

Single lip seal with the labyrinth between the sheet part and the rubber lip which conducts the contact sealing. The friction and speeds are the same as with RS but provides much better protection against the rough impurity particles. This is very good sealing system: the sheet part protects the seal from the soil, dust and rough particles. At the same time makes the labyrinth with the rubber part. The rubber part provides contact sealing which prevents penetration of finer impurities, water, moisture, steam etc. Suitable for neutral conditions because of the presence of the foreign materials. It is used with the Y bearing (standard) and deep groove ball bearings.

