

Y-Bearing Flanged Units With Round Grey Cast Iron Housing "G"

LSG 205 2F

Y-Bearing Flanged Units With Round Grey Cast Iron Housing "G"

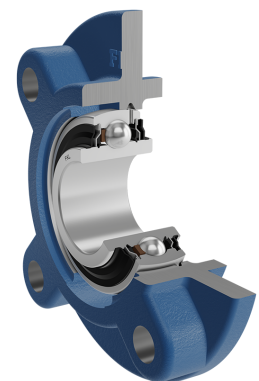
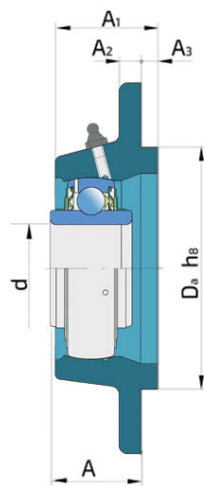
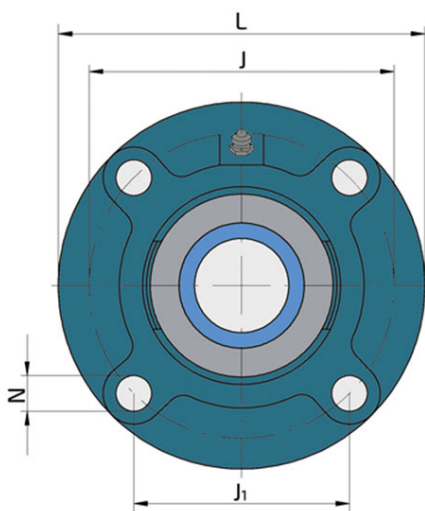

Technical Specification

d	Bore diameter	25 mm
Da	Centering diameter	70 mm
L	Overall width	115 mm
A	Distance from the housing flange to the front of the inner ring of the bearing	20.5 mm
A1	Total housing width	27 mm
A2	Housing flange thickness	7 mm
A3	Centering diameter height	6 mm
J	Pitch circle diameter	90 mm
J1	Distance between the holes	63.6 mm
N	Diameter of attachment slot	12 mm
kg	Mass	0.93 kg
Cdyn	Dynamic load rating	14 kN
Co	Static load rating	7.8 kN
Pu	Fatigue load limit	0.335 kN

Sealing

F SEAL / F SEAL (2F)

Dual sealing, protection cover placed on the inner ring protects against rough impurity particles and makes the labyrinth with the sheet part of the seal; then the sealing S type,

with the labyrinth between the sheet part and the rubber lip that conducts the contact sealing. The friction and speeds are the same as with S but has much better protection

against rough impurity particles. It is very good sealing system: the sheet part protects the seal from the soil, dust and

rough particles. At the same time makes the labyrinth with the rubber part. The rubber part provides the contact sealing that prevents the penetration of the finer impurities, water, moisture, steam etc. Suitable for heavier conditions due to better protection against foreign matters. It is used with the Y bearings (standard).

