

# Y-Bearing Flanged Units With Oval Grey Cast Iron Housing "N"

## LSN 205 2F

Y-Bearing Flanged Units With Oval Grey Cast Iron Housing "N"

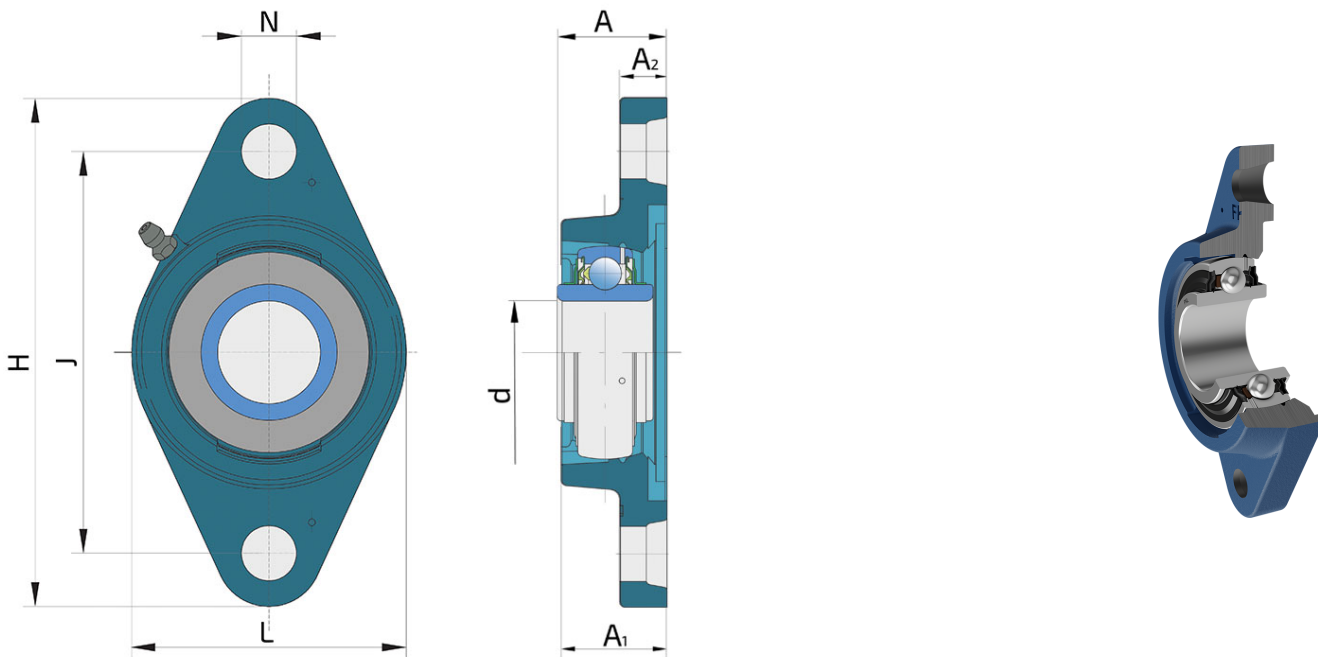
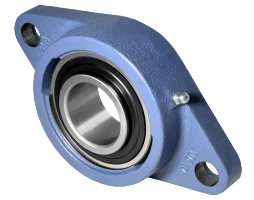

### Technical Specification

d	Bore diameter	25 mm
L	Overall width	68 mm
A	Distance from the housing flange to the front of the inner ring of the bearing	28 mm
A1	Total housing width	27 mm
A2	Housing flange thickness	14 mm
H	Housing height	130 mm
J	Pitch circle diameter	99 mm
N	Diameter of attachment slot	16 mm
kg	Mass	0.56 kg
C <sub>dyn</sub>	Dynamic load rating	14 kN
C <sub>o</sub>	Static load rating	7.8 kN
P <sub>u</sub>	Fatigue load limit	0.335 kN

## Sealing

---

### F SEAL / F SEAL (2F)

Dual sealing, protection cover placed on the inner ring protects against rough impurity particles and makes the labyrinth with the sheet part of the seal; then the sealing S type,

with the labyrinth between the sheet part and the rubber lip that conducts the contact sealing. The friction and speeds are the same as with S but has much better protection

against rough impurity particles. It is very good sealing system: the sheet part protects the seal from the soil, dust and

rough particles. At the same time makes the labyrinth with the rubber part. The rubber part provides the contact sealing that prevents the penetration of the finer impurities, water, moisture, steam etc. Suitable for heavier conditions due to better protection against foreign matters. It is used with the Y bearings (standard).

