

Y-Bearing Plummer Block Units With Grey Cast Iron Housing "V"

LYV 209 2F

Y-Bearing Plummer Block Units With Grey Cast Iron Housing "V"

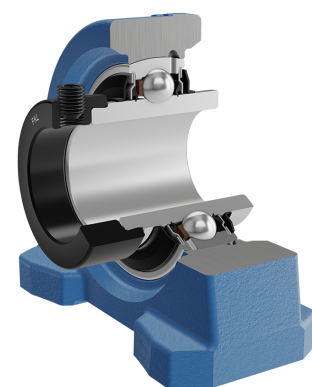
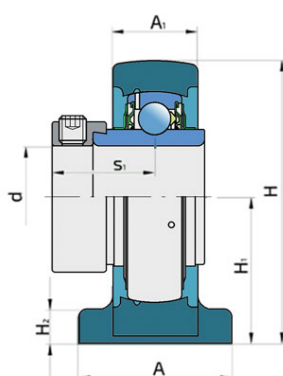
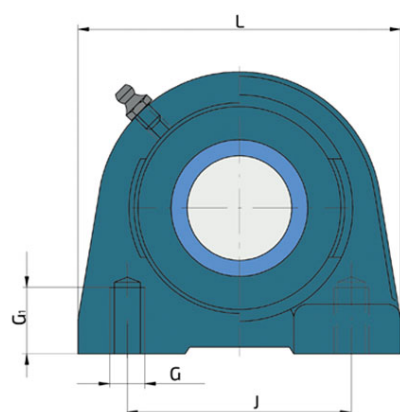
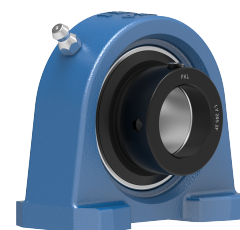

Technical Specification

| | | |
|------|----------------------------------------------------------|----------|
| d | Bore diameter | 45 mm |
| L | Overall length | 120 mm |
| A | Housing contact surface width | 54 mm |
| A1 | Width of the top of the housing | 33.5 mm |
| H | Housing height | 54.2 mm |
| H1 | Distance from the contact surface to the bearing axis | 12 mm |
| H2 | Housing foot thickness | 108 mm |
| J | Pitch circle diameter | 90 mm |
| G | Thread | M17 mm |
| G1 | Thread length | 25 mm |
| s1 | Distance from locking device side face to raceway centre | 34.9 mm |
| kg | Mass | 1.91 kg |
| Cdyn | Dynamic load rating | 33.2 kN |
| Co | Static load rating | 21.6 kN |
| Pu | Fatigue load limit | 0.915 kN |

Sealing

F SEAL / F SEAL (2F)

Dual sealing, protection cover placed on the inner ring protects against rough impurity particles and makes the labyrinth with the sheet part of the seal; then the sealing S type,

with the labyrinth between the sheet part and the rubber lip that conducts the contact sealing. The friction and speeds are the same as with S but has much better protection

against rough impurity particles. It is very good sealing system: the sheet part protects the seal from the soil, dust and

rough particles. At the same time makes the labyrinth with the rubber part. The rubber part provides the contact sealing that prevents the penetration of the finer impurities, water, moisture, steam etc. Suitable for heavier conditions due to better protection against foreign matters. It is used with the Y bearings (standard).

