

Y-Bearing Plummer Block Units With Grey Cast Iron Housing "S"

LES 210 2F

Y-Bearing Plummer Block Units With Grey Cast Iron Housing "S"

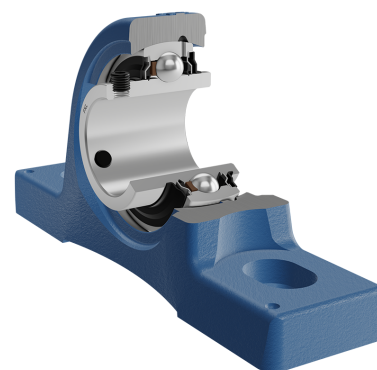
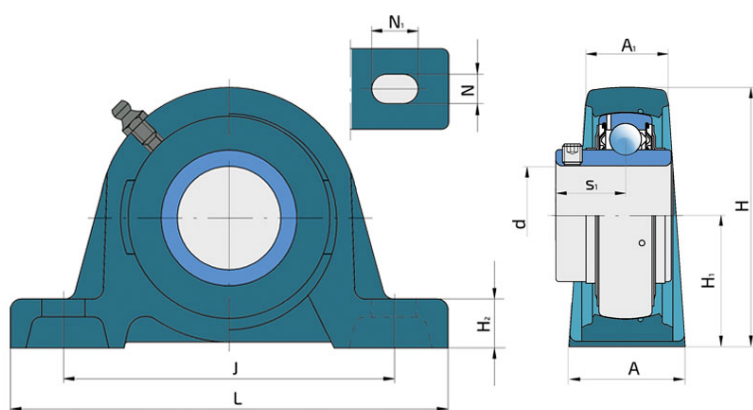
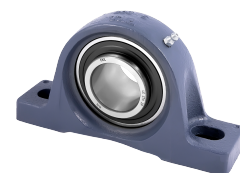

Technical Specification

d	Bore diameter	50 mm
L	Overall length	206 mm
A	Housing contact surface width	58 mm
A1	Width of the top of the housing	38 mm
H	Housing height	113.2 mm
H1	Distance from the contact surface to the bearing axis	57.2 mm
H2	Housing foot thickness	22 mm
Jmin	Min. distance between the holes	151 mm
Jmax	Max. distance between the holes	164 mm
N	Height of attachment slot	20 mm
N1	Length attachment end	26.5 mm
s1	Distance from locking device side face to raceway centre	32.6 mm
kg	Mass	2.74 kg
Cdyn	Dynamic load rating	35.1 kN
Co	Static load rating	23.2 kN
Pu	Fatigue load limit	0.98 kN

Sealing

F SEAL / F SEAL (2F)

Dual sealing, protection cover placed on the inner ring protects against rough impurity particles and makes the labyrinth with the sheet part of the seal; then the sealing S type,

with the labyrinth between the sheet part and the rubber lip that conducts the contact sealing. The friction and speeds are the same as with S but has much better protection

against rough impurity particles. It is very good sealing system: the sheet part protects the seal from the soil, dust and

rough particles. At the same time makes the labyrinth with the rubber part. The rubber part provides the contact sealing that prevents the penetration of the finer impurities, water, moisture, steam etc. Suitable for heavier conditions due to better protection against foreign matters. It is used with the Y bearings (standard).

