

Y-Bearing Plummer Block Units With Grey Cast Iron Housing "S"

UES 208 2S

Y-Bearing Plummer Block Units With Grey Cast Iron Housing "S"

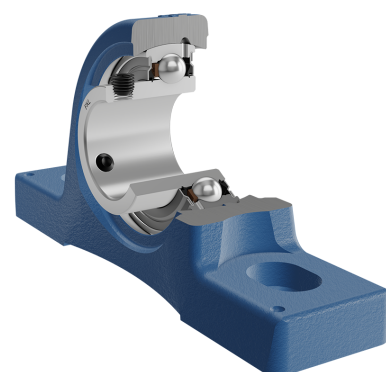
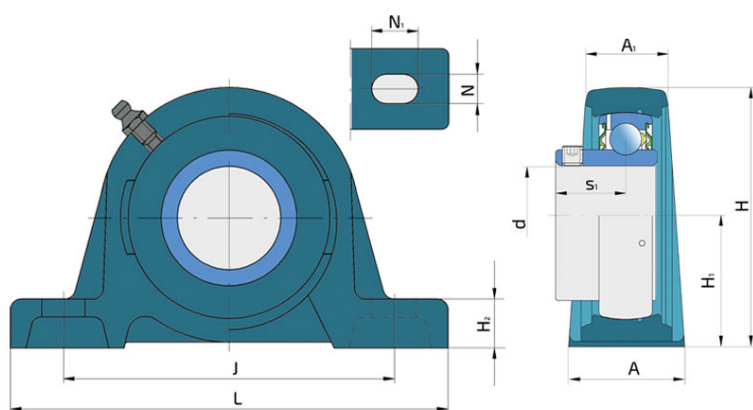
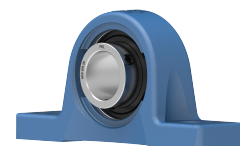

Technical Specification

d	Bore diameter	40 mm
L	Overall length	184 mm
A	Housing contact surface width	49 mm
A1	Width of the top of the housing	31 mm
H	Housing height	98.2 mm
H1	Distance from the contact surface to the bearing axis	49.2 mm
H2	Housing foot thickness	18 mm
Jmin	Min. distance between the holes	128 mm
Jmax	Max. distance between the holes	145 mm
N	Height of attachment slot	17 mm
N1	Length attachment end	25.5 mm
s1	Distance from locking device side face to raceway centre	25.3 mm
kg	Mass	1.85 kg
Cdyn	Dynamic load rating	30.7 kN
Co	Static load rating	19 kN
Pu	Fatigue load limit	0.8 kN

Sealing

S SEAL / S SEAL (2S)

Single lip seal with the labyrinth between the sheet part and the rubber lip which conducts the contact sealing. The friction and speeds are the same as with RS but provides much better protection against the rough impurity particles. This is very good sealing system: the sheet part protects the seal from the soil, dust and rough particles. At the same time makes the labyrinth with the rubber part. The rubber part provides contact sealing which prevents penetration of finer impurities, water, moisture, steam etc. Suitable for neutral conditions because of the presence of the foreign materials. It is used with the Y bearing (standard) and deep groove ball bearings.

