

Y-Ball Bearings With Adapter Sleeve

LK 215 2F+H 2315

Y-Ball Bearings With Adapter Sleeve

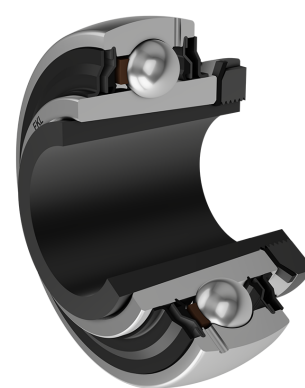
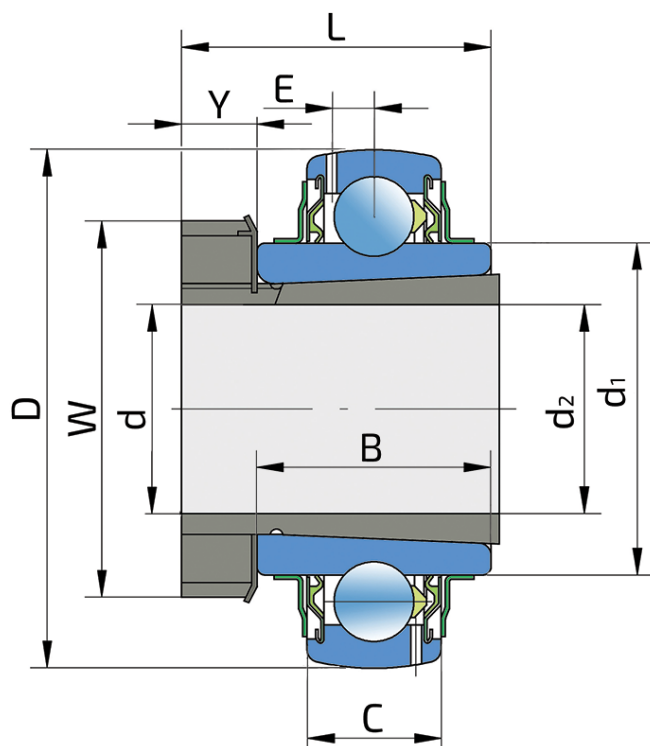

Technical Specification

| | | |
|------------------|--|---------|
| d | Bore diameter | 75 mm |
| D | Outside diameter | 130 mm |
| B | Width inner ring | 41 mm |
| C | Width outer ring | 29 mm |
| d1 | Outer diameter inner ring | 92.1 mm |
| E | Distance from raceway centre to the hole for lubrication | 8.3 mm |
| d2 | Bore diameter-adapter sleeve | 65 mm |
| L | Width adapter sleeve | 73 mm |
| W | KM nut outside diameter | 98 mm |
| Y | KM nut width | 15 mm |
| C _{dyn} | Dynamic load rating | 62 kN |
| C _o | Static load rating | 44.5 kN |
| P _u | Fatigue load limit | 1.44 kN |
| kg | Mass | 2.59 kg |

Sealing

F SEAL / F SEAL (2F)

Dual sealing, protection cover placed on the inner ring protects against rough impurity particles and makes the labyrinth with the sheet part of the seal; then the sealing S type,

with the labyrinth between the sheet part and the rubber lip that conducts the contact sealing. The friction and speeds are the same as with S but has much better protection

against rough impurity particles. It is very good sealing system: the sheet part protects the seal from the soil, dust and

rough particles. At the same time makes the labyrinth with the rubber part. The rubber part provides the contact sealing that prevents the penetration of the finer impurities, water, moisture, steam etc. Suitable for heavier conditions due to better protection against foreign matters. It is used with the Y bearings (standard).

