

Integrated Flange, Maintenance Free Bearing

IL40-110/4H-M24x1.5

Integrated Flange, Maintenance Free Bearing
Disc Harrow

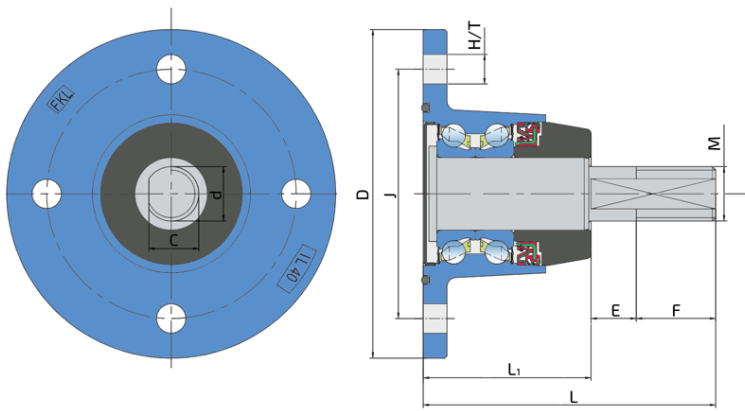

Technical Specification

J	Pitch circle diameter	110 mm
D	Outside diameter	145 mm
H/T	Hole/Thread	4x13 mm
d	Bore diameter	24 mm
C	D-shape hole cut out dimension	22.5 mm
M	Outer Thread	M24x1.5 mm
L	Total length	129 mm
L1	Total flange length	74 mm
E	Length of D shape	20 mm
F	Length of threaded part	35 mm
kg	Mass	2.81 kg
C _{dyn}	Dynamic load rating	42.9 kN
C _o	Static load rating	36.3 kN
P _u	Fatigue load limit	1.53 kN

Sealing

O-RING+SHEET METAL SHIELD+RS SEAL / RS SEAL+DIRTBLOCK SEAL+FORGED COVER PLATE

O-ring, Sheet metal shield and RS seal on the base side and RS seal, Dirtblock seal with Forged cover plate on the front side which is exposed to contaminants.

O-ring, Sheet metal shield and RS seal together with attached disc eliminates the possibility of contamination from the base side.

Dirtblock seal is designed for hard working condition at unfriendly environment. Half metal - half rubber outside diameter provides reliable seal retention in the bore and improves sealing performance. Inside diameter is covered by rubber and improves sealing performance and easy installation. Forged cover plate is additional, strong protection of the Dirtblock seal against mechanical damage.

This sealing provides maximum protection against liquid or solid contaminants, which significantly extends bearing service life.

