

# The Bearing Solution For Seeding Machines, Integrated Flange

## IL20-82/5T-B16

The Bearing Solution For Seeding Machines, Integrated Flange  
Seed drill

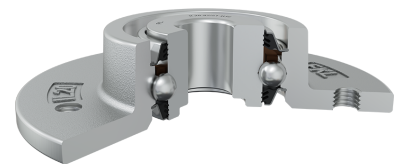
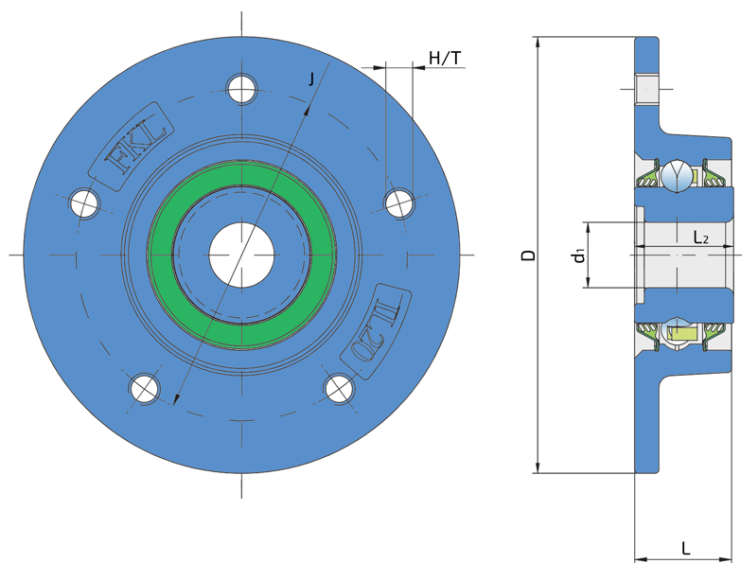

### Technical Specification

J	Pitch circle diameter	82 mm
D	Outside diameter	108 mm
H/T	Hole/Thread	5xM8 mm
d1	Bore diameter	16.2 mm
L	Total length	24.5 mm
L2	Bearing width	24.5 mm
kg	Mass	0.64 kg
Cdyn	Dynamic load rating	22 kN
Co	Static load rating	15.2 kN
Pu	Fatigue load limit	0.638 kN

## Sealing

---

### T SEAL / T SEAL (2T)

3-lip seal on the both side of the bearing, provides equal protection against contamination. Recommended for application where the possibility of contamination is the same on the both side.

