

Bearing Unit

LSQFR 308 TDT.H.T

Bearing Unit
Packer Roller

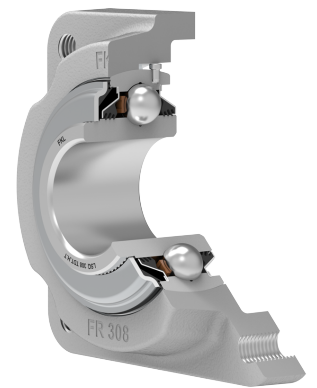
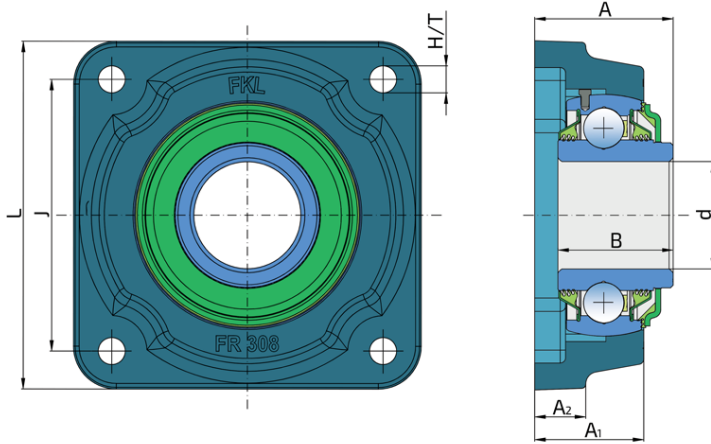

Technical Specification

| | | |
|------|----------------------------|----------|
| d | Bore diameter | 40 mm |
| L | Total length | 130 mm |
| J | Distance between the holes | 101.5 mm |
| H/T | Hole/Thread | M12 mm |
| A | Overall width | 51.4 mm |
| A1 | Total housing width | 40.6 mm |
| A2 | Housing flange thickness | 19 mm |
| B | Width inner ring | 42.9 mm |
| kg | Mass | 2.5 kg |
| Cdyn | Dynamic load rating | 62.3 kN |
| Co | Static load rating | 45.2 kN |
| Pu | Fatigue load limit | 1.898 kN |

Sealing

DOUBLE T SEAL / T SEAL

3-lip seal on the base side and double 3-lip seal on the front side which is exposed to contaminants.

The double 3-lip seal on the front side protects the bearing from contaminant penetration. Also, the outer seal with 3 lips, with additional sealing, protects the inner seal from mechanical damage.

