

The Bearing Solution For Seeding Machines, Integrated Flange

IL20/305-70/6T-B16

The Bearing Solution For Seeding Machines, Integrated Flange
Seeding Machine

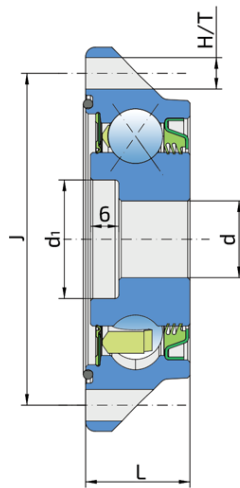
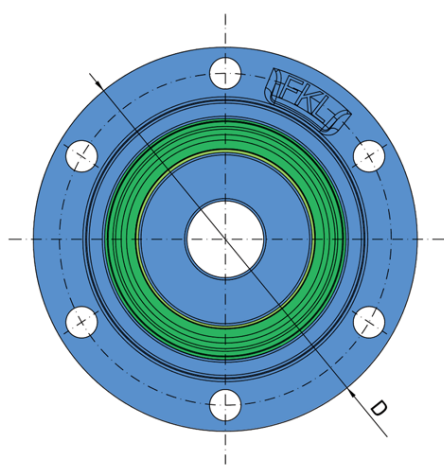

Technical Specification

J	Pitch circle diameter	70 mm
D	Outside diameter	81 mm
H/T	Hole/Thread	6xM8 mm
d	Bore diameter	16.2 mm
d1	Bore diameter	25 mm
L	Total length	22 mm
kg	Mass	0.45 kg
Cdyn	Dynamic load rating	34.5 kN
Co	Static load rating	54.8 kN
Pu	Fatigue load limit	2.302 kN

Sealing

O-RING + RS SEAL / T SEAL

O-ring with an RS seal on the base side and the 3-lip seal on the front side. O-ring with an RS seal on the base is also protected with an attached disc, protecting the bearing from contamination. 3-lip seal on the front side eliminates bearing contaminants.

