

Four Point Contact Ball Bearing

SLU 53-012-2T

Four Point Contact Ball Bearing
Seeding Machine

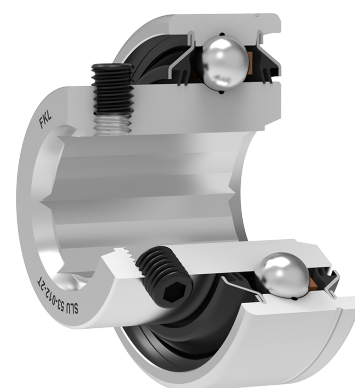
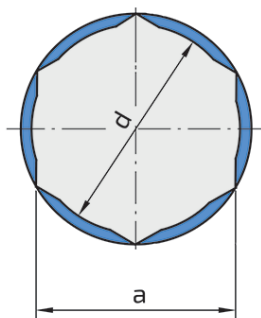
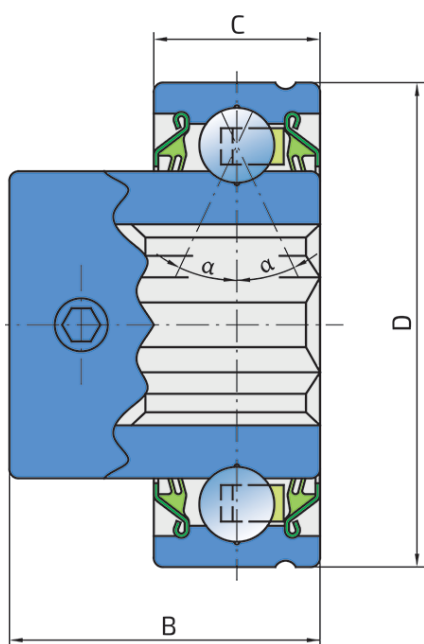
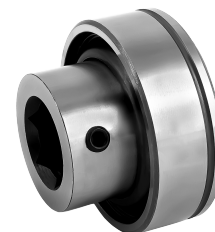

Technical Specification

C _{dyn}	Dynamic load rating	14 kN
C _o	Static load rating	7.8 kN
D	Outside diameter	53.086 mm
d	Bore diameter	19.6 mm
C	D-shape hole cut out dimension	18.288 mm
kg	Mass	0.257 kg
B	Width inner ring	34.2 mm
α	Contact angle	25 °
a	Shaft size	19.18 inch

Sealing

D SEAL / D SEAL (2D)

The double lip seal provides twice as good a seal as the S seal, while the maximum permitted rotational speed is adequately lower, due to the greater friction of the rubber lips against the steel inner ring. However, this rotational speed may be higher than with a 3-lip seal, up to 1500rpm. The sheet metal part protects the seal from the soil, dust and rough particles. At the same time makes the labyrinth with the rubber part. The main area of application of bearings with such sealing are agricultural and construction machines at installation place where the rotational speed is up to 1500 rpm.

