

The Bearing Solution For Seeding Machines, Integrated Flange

IL20S-76.2/6H-B16-2T

The Bearing Solution For Seeding Machines, Integrated Flange
Seeding Machine

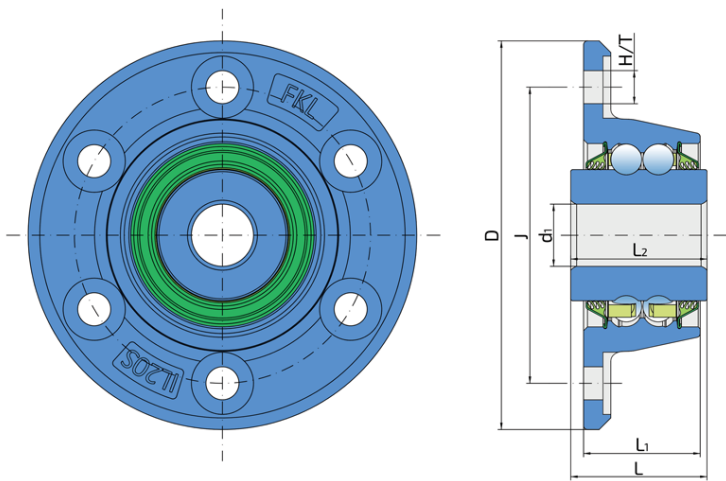

Technical Specification

| | | |
|------|-----------------------|----------|
| J | Pitch circle diameter | 76.2 mm |
| D | Outside diameter | 100 mm |
| H/T | Hole/Thread | 6x8.5 mm |
| d1 | Bore diameter | 16 mm |
| L | Overall length | 35 mm |
| L1 | Total flange length | 30 mm |
| L2 | Bearing width | 35 mm |
| kg | Mass | 0.68 kg |
| Cdyn | Dynamic load rating | 22 kN |
| Co | Static load rating | 15.2 kN |
| Pu | Fatigue load limit | 0.638 kN |

Sealing

T SEAL / T SEAL (2T)

3-lip seal on the both side of the bearing, provides equal protection against contamination. Recommended for application where the possibility of contamination is the same on the both side.

