

Bearing Unit

LEFN 208 2TC

Bearing Unit
Universal Solution

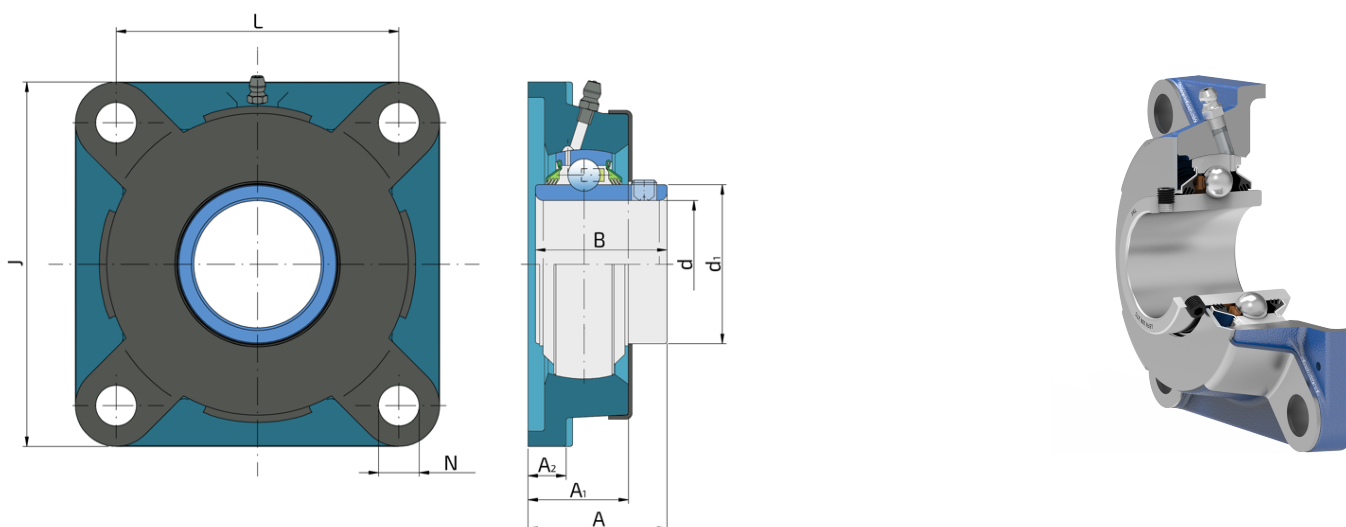

Technical Specification

d	Bore diameter	40 mm
d1	Outer diameter inner ring	51.8 mm
L	Total length	130 mm
J	Distance between the holes	102 mm
N	Hole diameter	16 mm
A	Overall width	51.6 mm
A1	Total housing width	36 mm
A2	Housing flange thickness	11 mm
B	Width inner ring	49.2 mm
kg	Mass	2.1 kg
Cdyn	Dynamic load rating	30.7 kN
Co	Static load rating	19 kN
Pu	Fatigue load limit	0.798 kN

Sealing

T SEAL / T SEAL+METAL COVER

3-lip seal on the base side and 3-lip seal with Metal cover on the front side which is exposed to contaminants.

The 3-lip seal on the front side protects the bearing from contaminant penetration.

The Metal cover protects the seal from mechanical damage and from entanglement of grass stems of plants and twines.

