

Integrated double row, split inner ring ball bearing

IL60C-150/6T-D95-LH

Integrated double row, split inner ring ball bearing
Cultivators

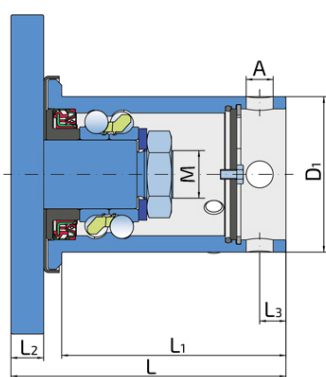
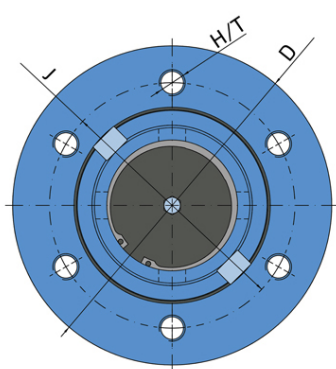

Technical Specification

D	Outside diameter	195 mm
J	Pitch circle diameter	150 mm
H/T	Hole/Thread	6xM16 mm
M	Outer Thread	M30x1.5-LH mm
L	Total length	168 mm
L1	The length of the sleeve	137 mm
L2	Flange thickness	20 mm
L3	The distance from the face of the sleeve to the axis of the locking hole	16 mm
A	Locking hole diameter	4x16.5 mm
D1	Outer diameter of the sleeve	95 mm
kg	Mass	9.74 kg
Cdyn	Dynamic load rating	75.86 kN
Co	Static load rating	66.2 kN
Pu	Fatigue load limit	2.78 kN

Sealing

SHEET METAL SHIELD + FORGED COVER PLATE + DIRTBLOCK SEAL / O-RING + COVER PLATE

Sheet metal shield, forged cover plate and dirtblock seal on the base side and o-ring with cover plate on the front side. Sheet metal shield, forged cover plate and dirtblock seal together eliminates the possibility of contamination from the base side. Dirtblock seal is designed for hard working condition at unfriendly environment. Half metal & half rubber outside diameter provides reliable seal retention in the bore and improves sealing performance. Inside diameter is covered by rubber and improves sealing performance and easy installation. Forged cover plate is additional, strong protection of the Dirtblock seal against mechanical damage. This sealing provides maximum protection against liquid or solid contaminants, which significantly extends bearing service life.

