

Bearing Unit

PL-185-M30-L+M30x1.5-LH

Bearing Unit
Disc Harrow

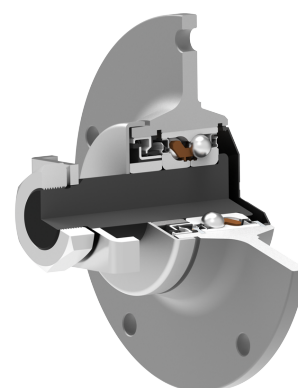
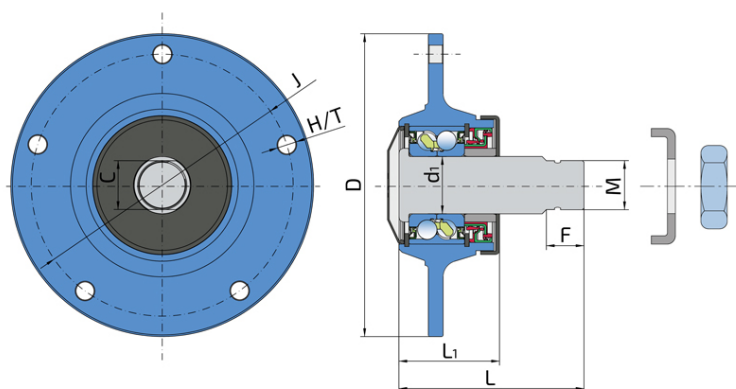

Technical Specification

| | | |
|------|--------------------------------|---------------|
| D | Outside diameter | 185 mm |
| d1 | Bore diameter | 35 mm |
| C | D-shape hole cut out dimension | 30 mm |
| J | Pitch circle diameter | 160 mm |
| H/T | Hole/Thread | 12 mm |
| L | Diameter of housings | 113 mm |
| L1 | Total flange length | 61.6 mm |
| F | Length of threaded part | 23 mm |
| M | Outer Thread | M30x1.5-LH mm |
| kg | Mass | 4 kg |
| Cdyn | Dynamic load rating | 47.4 kN |
| Co | Static load rating | 38.3 kN |
| Pu | Fatigue load limit | 1.609 kN |

Sealing

PLASTIC CAP + CASSETTE SEAL / CASSETTE SEAL + DIRTBLOCK SEAL + METAL SHIELD

Two part double lip wheel bearing seal on the both side. This sealing provides excellent protection from contamination and low friction.

Front side is totally sealed with a polypropylene shield which prevents all kind of contaminations.

The other side is additionally protected with dirtblock seal and with a metal protective cap. Dirtblock seal is designed for hard working condition, half metal – half rubber outside diameter provides reliable seal retention in the bore and improves sealing performance. Inside diameter is covered by rubber and improves sealing performance and easy installation. The metal protective cap protects the seal from mechanical damage and from entanglement of grass stems of plants and twines.

This sealing provides maximum protection against liquid or solid contaminants, which significantly extends bearing service life.

