

The Bearing Solution For Seeding Machines, Integrated Flange And Shaft

IL10-60/6T-M16-RH

The Bearing Solution For Seeding Machines, Integrated Flange And Shaft
Seeding Machines

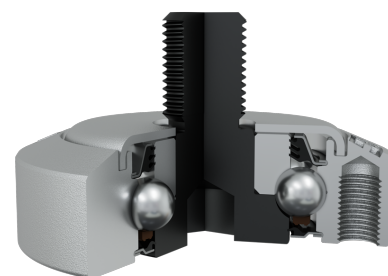
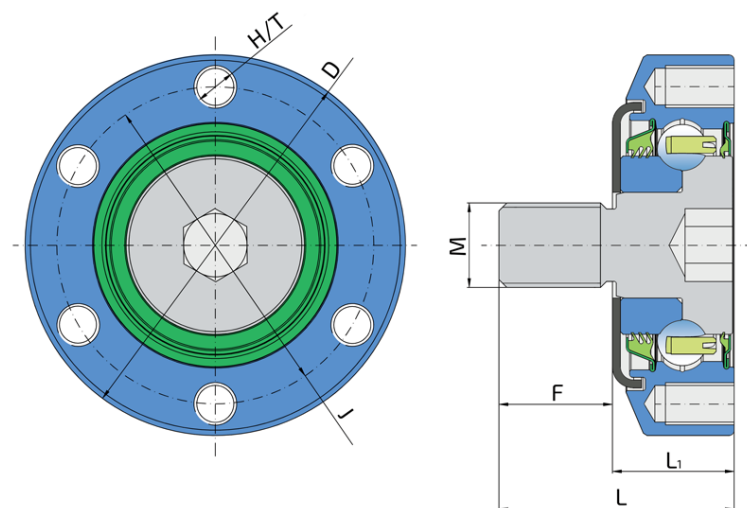

Technical Specification

J	Pitch circle diameter	60 mm
D	Outside diameter	72 mm
H/T	Hole/Thread	6xM8x1 mm
M	Outer Thread	M16x1.5 right hand mm
L	Total length	44.5 mm
L1	Total flange length	23 mm
F	Length of threaded part	21.5 mm
kg	Mass	0.59 kg
Cdyn	Dynamic load rating	32 kN
Co	Static load rating	22 kN
Pu	Fatigue load limit	0.924 kN

Sealing

S SEAL / T SEAL + METAL SHIELD

S seal on the base side and the 3-lip seal with Metal shield on the front side.
S seal on the base side protecting the bearing from contamination.
3-lip seal with a Metal shield on the front side eliminates bearing contaminants.

