

The Bearing Solution For Seeding Machines, Integrated Flange

IL25-75/6H-B20

The Bearing Solution For Seeding Machines, Integrated Flange

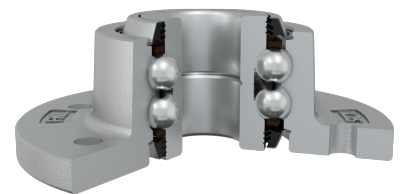
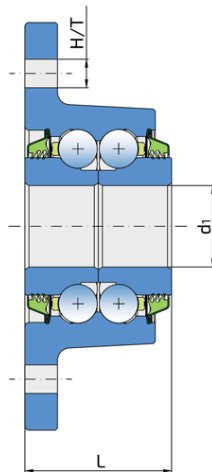
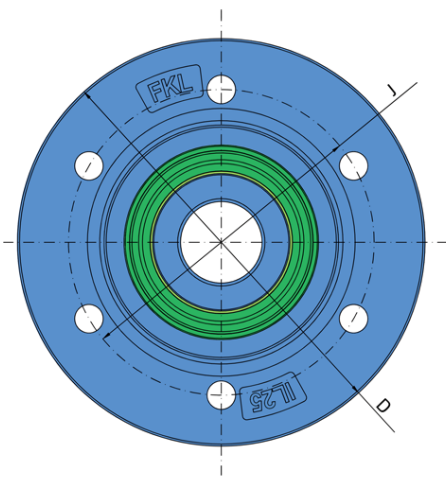

Technical Specification

J	Pitch circle diameter	75 mm
D	Outside diameter	100 mm
H/T	Hole/Thread	5x7 mm
d1	Bore diameter	20 mm
L	Total length	36 mm
kg	Mass	0.78 kg
C _{dyn}	Dynamic load rating	32 kN
C _o	Static load rating	22 kN
P _u	Fatigue load limit	0.924 kN

Sealing

T SEAL / T SEAL (2T)

3-lip seal on the both side of the bearing, provides equal protection against contamination. Recommended for application where the possibility of contamination is the same on the both side.

