

Bearing Unit

LEFN 207 2T

Bearing Unit
Universal Solution

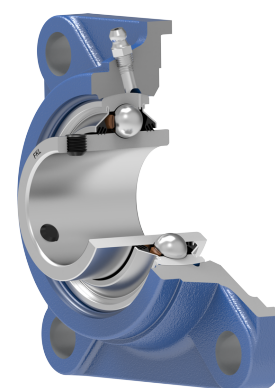
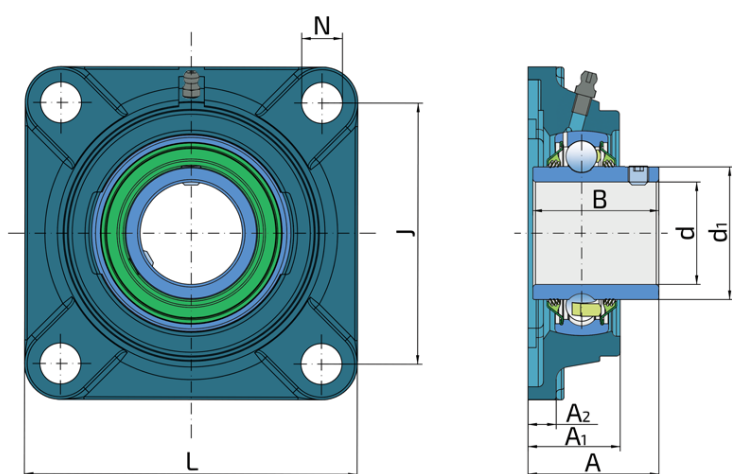

Technical Specification

d	Bore diameter	35 mm
d1	Outer diameter inner ring	46.1 mm
L	Total length	118 mm
J	Distance between the holes	92 mm
N	Hole diameter	14 mm
A	Overall width	44.4 mm
A1	Total housing width	34 mm
A2	Housing flange thickness	13 mm
B	Width inner ring	42.9 mm
kg	Mass	1.4 kg
Cdyn	Dynamic load rating	25.5 kN
Co	Static load rating	15.3 kN
Pu	Fatigue load limit	0.643 kN

Sealing

T SEAL / T SEAL (2T)

3-lip seal on the both side of the bearing, provides equal protection against contamination. Recommended for application where the possibility of contamination is the same on the both side.

