

LE 212 TDT

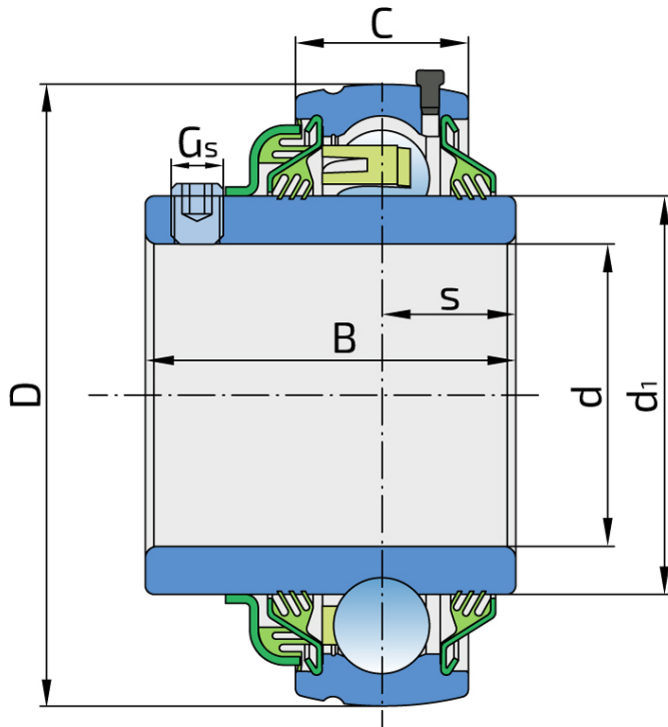

Technical Specification

d	Bore diameter	60 mm
D	Outside diameter	110 mm
B	Width inner ring	65.1 mm
C	Width outer ring	26 mm
s	Distance from inner ring side face to raceway centre	25.4 mm
d1	Outer diameter inner ring	75.64 mm
Gs	Set screw	M10x1 mm
kg	Mass	1.42 kg
C _{dyn}	Dynamic load rating	52 kN
C _o	Static load rating	36 kN
P _u	Fatigue load limit	1.512 kN

Sealing

DOUBLE T SEAL / T SEAL

3-lip seal on the base side and double 3-lip seal on the front side which is exposed to contaminants. The double 3-lip seal on the front side protects the bearing from contaminant penetration. Also, the outer seal with 3 lips, with additional sealing, protects the inner seal from mechanical damage.

