

# Trunnion Bearing Units

## GWHG 211PP25

Trunnion Bearing Units  
Disc Harrow

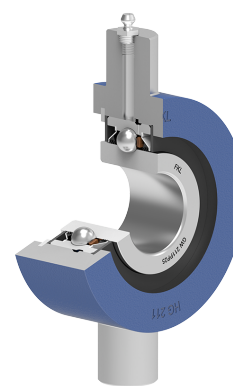
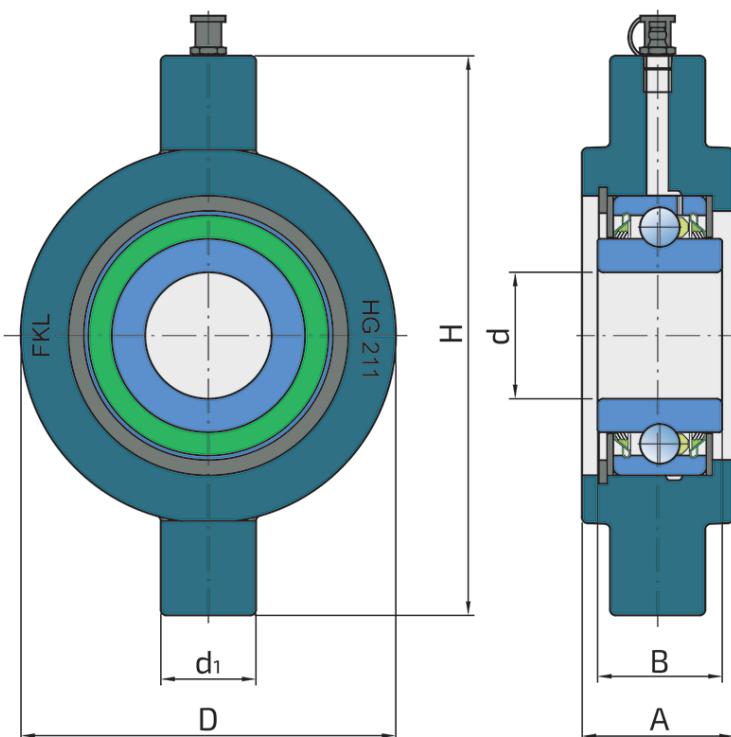

### Technical Specification

C <sub>dyn</sub>	Dynamic load rating	43.5 kN
C <sub>o</sub>	Static load rating	29 kN
D	Outside diameter	134 mm
d	Bore diameter	45.212 mm
d <sub>1</sub>	Bearing housing sleeve diameter	34 mm
kg	Mass	4.88 kg
H	Housing height	200 mm
B	Width inner ring	44.5 mm
A	Overall width	54 mm

## Sealing

---

### T SEAL / T SEAL (2T)

3-lip seal on the both side of the bearing, provides equal protection against contamination. Recommended for application where the possibility of contamination is the same on the both side.

