

The Bearing Solution For Harsh Seeding Conditions And Coulter Discs Of Ploughs, Integrated Flange

IL30-85/4H-M22-04

The Bearing Solution For Harsh Seeding Conditions And Coulter Discs Of Ploughs, Integrated Flange

Seeding machines for No-till and Strip-till farming technology; Coulter discs for seeding machines; Marker discs for ploughs

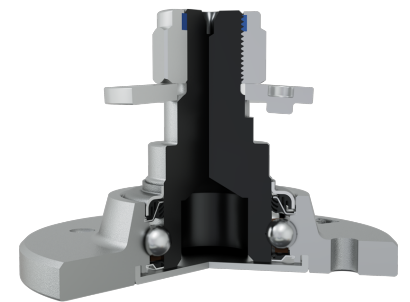
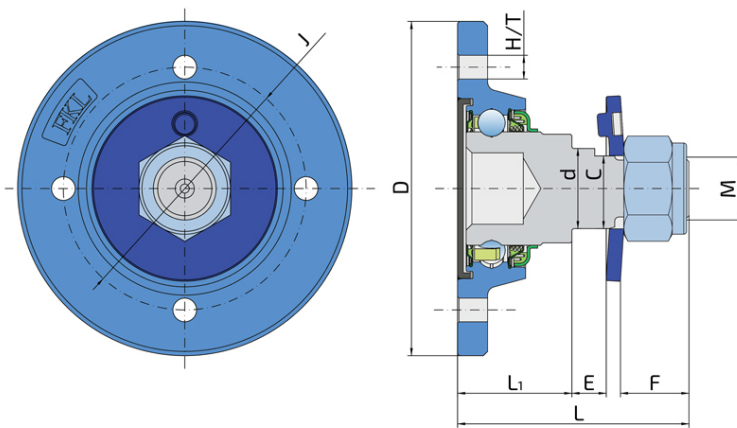

Technical Specification

J	Pitch circle diameter	85 mm
D	Outside diameter	117 mm
H/T	Hole/Thread	4x8.3 mm
d	Bore diameter	28 mm
C	D-shape hole cut out dimension	25.4 mm
M	Outer Thread	M22x1.5 mm
L	Total length	81 mm
L1	Total flange length	40 mm
E	Length of D shape	12 mm
F	Length of threaded part	26 mm
kg	Mass	1.499 kg
Cdyn	Dynamic load rating	29.6 kN
Co	Static load rating	21 kN
Pu	Fatigue load limit	0.882 kN

Sealing

SHEET METAL SHIELD + S SEAL / DOUBLE T SEAL + STEEL SHIELD

Sheet metal shield and S seal on the base side and the double 3-lip seal with Steel shield on the front side.

Sheet metal shield and S seal on the base side completely excludes all contaminants.

Double 3-lip seal protects the front side much longer than the just comparing to the regular one 3-lip seal. Steel shield is additional, strong protection of the double 3-lip seal against mechanical damage.

