

# Bearing Unit

## LEFN 210 2PC.H

Bearing Unit  
Universal Solution

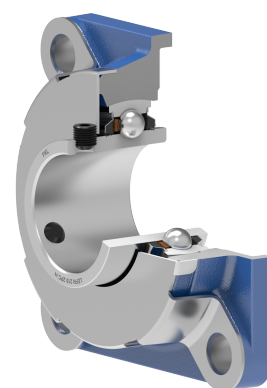
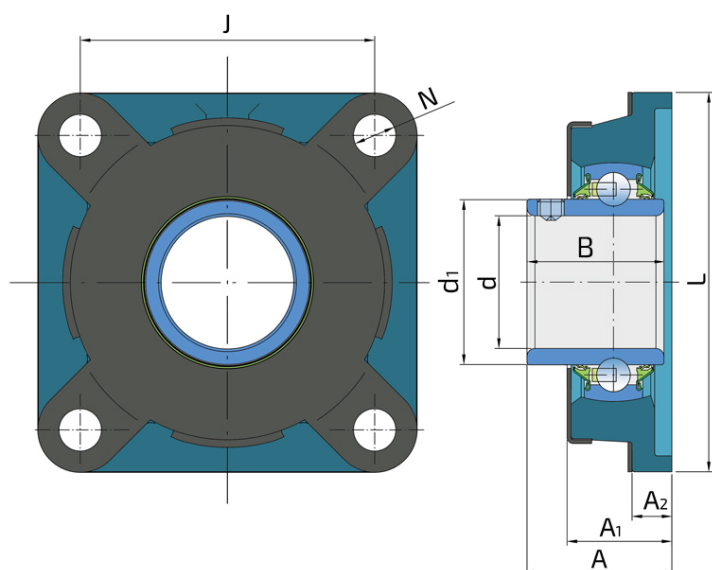

### Technical Specification

d	Bore diameter	50 mm
d1	Outer diameter inner ring	62.5 mm
L	Total length	143 mm
J	Distance between the holes	111 mm
N	Hole diameter	16 mm
A	Overall width	54.6 mm
A1	Total housing width	38 mm
A2	Housing flange thickness	15 mm
B	Width inner ring	51.6 mm
kg	Mass	2.8 kg
Co	Static load rating	23.2 kN
Cdyn	Dynamic load rating	35.1 kN
Pu	Fatigue load limit	0.974 kN

## Sealing

---

### P SEAL / P SEAL + METAL COVER

5-lip seal on the base side and 5-lip seal with Metal cover on the front side which is exposed to contaminants. The 5-lip seal on the front side protects the bearing from contaminant penetration. The Metal cover protects the seal from mechanical damage and from entanglement of grass stems of plants and twines.

