

# Round Series

## GWST 211PPB20

Round Series  
Disc Harrow

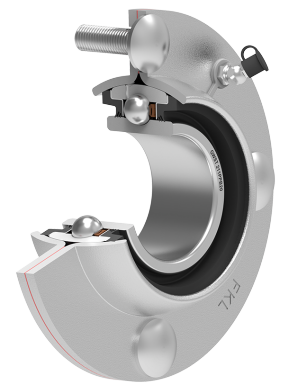
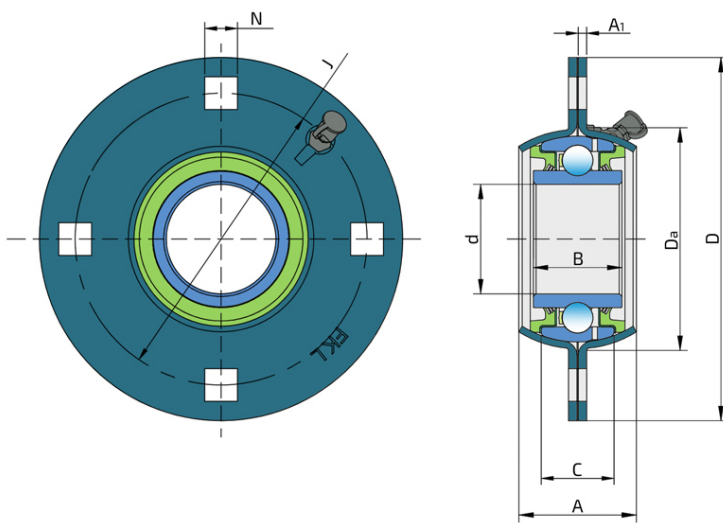

### Technical Specification

d	Bore diameter	2.193 inch
d	Bore diameter	55.7 mm
B	Width inner ring	39.7 mm
A	Overall width	56.5 mm
A1	Width of the top of the housing	3.5 mm
C	Width outer ring	33.4 mm
Da	Centering diameter	111 mm
D	Outside diameter	167 mm
J	Pitch circle diameter	138 mm
N	Hole diameter	13.5 mm
kg	Mass	2.706 kg
C <sub>dyn</sub>	Dynamic load rating	43.5 kN
C <sub>o</sub>	Static load rating	29 kN
P <sub>u</sub>	Fatigue load limit	1.218 kN

## Sealing

---

### T SEAL / T SEAL (2T)

3-lip seal on the both side of the bearing, provides equal protection against contamination. Recommended for application where the possibility of contamination is the same on the both side.

