

# Maintenance-Free Bearing With Integrated Flange For Harsh Tillage

## IL70-170/6H-M33x2

Maintenance-Free Bearing With Integrated Flange For Harsh Tillage  
Disc Harrow

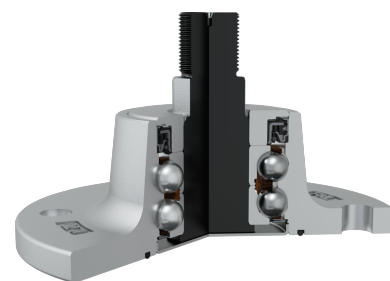
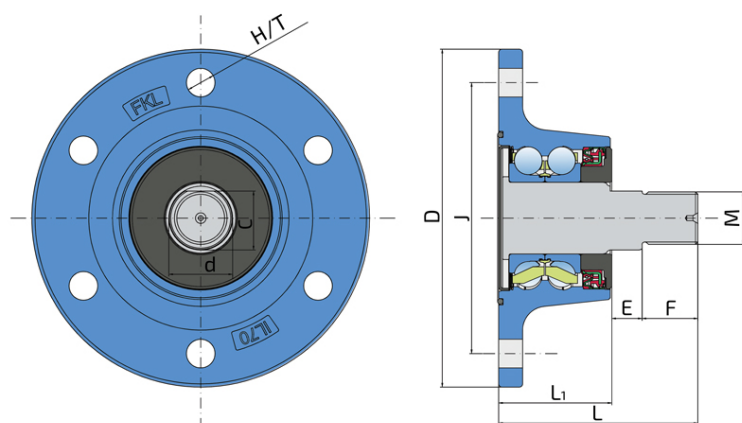

### Technical Specification

J	Pitch circle diameter	170 mm
D	Outside diameter	212 mm
H/T	Hole/Thread	6x18 mm
d	Bore diameter	40 mm
C	D-shape hole cut out dimension	37 mm
M	Outer Thread	M33x2 mm
L	Total length	125 mm
L1	Total flange length	71 mm
E	Length of D shape	19 mm
F	Length of threaded part	35 mm
kg	Mass	7.362 kg
C <sub>dyn</sub>	Dynamic load rating	94.45 kN
C <sub>o</sub>	Static load rating	77.88 kN
P <sub>u</sub>	Fatigue load limit	3.271 kN

## Sealing

### O-RING+SHEET METAL SHIELD+RS SEAL / DIRTBLOCK SEAL+FORGED COVER PLATE

O-ring, Sheet metal shield and RS seal on the base side and Dirtblock seal with Forged cover plate on the front side which is exposed to contaminants.

O-ring, Sheet metal shield and RS seal together with attached disc eliminates the possibility of contamination from the base side.

Dirtblock seal is designed for hard working condition at unfriendly environment. Half metal - half rubber outside diameter provides reliable seal retention in the bore and improves sealing performance. Inside diameter is covered by rubber and improves sealing performance and easy installation. Forged cover plate is additional, strong protection of the Dirtblock seal against mechanical damage.

This sealing provides maximum protection against liquid or solid contaminants, which significantly extends bearing service life.

