

The Bearing Solution For Seeding Machines, Integrated Flange

IL20S-75/4H-M16

The Bearing Solution For Seeding Machines, Integrated Flange
Seeding Machine

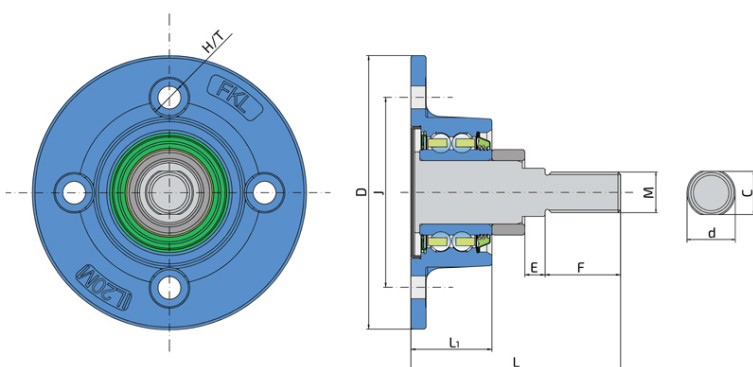

Technical Specification

J	Pitch circle diameter	75 mm
D	Outside diameter	108 mm
H/T	Hole/Thread	4x9 mm
d	Bore diameter	19 mm
C	D-shape hole cut out dimension	17 mm
M	Outer Thread	M16 mm
L	Total length	82.8 mm
L1	Total flange length	32 mm
E	Length of D shape	8 mm
F	Length of threaded part	29.8 mm
kg	Mass	0.973 kg
C _{dyn}	Dynamic load rating	21.6 kN
C _o	Static load rating	14.3 kN
P _u	Fatigue load limit	0.601 kN

Sealing

SHEET METAL SHIELD + RS SEAL / T SEAL

Sheet metal shield and RS seal on the base side and 3-lip seal on the front side. Sheet metal shield and RS seal together with attached disc eliminates the possibility of contamination from the base side. The 3-lip seal on the front side protects the bearing from contaminant penetration.

