

# AGRO POINT HUB

## IL60-115/6T-M20

AGRO POINT HUB  
Seeding Machine

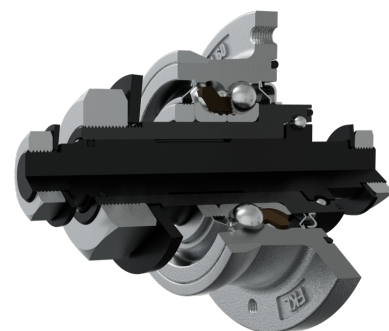
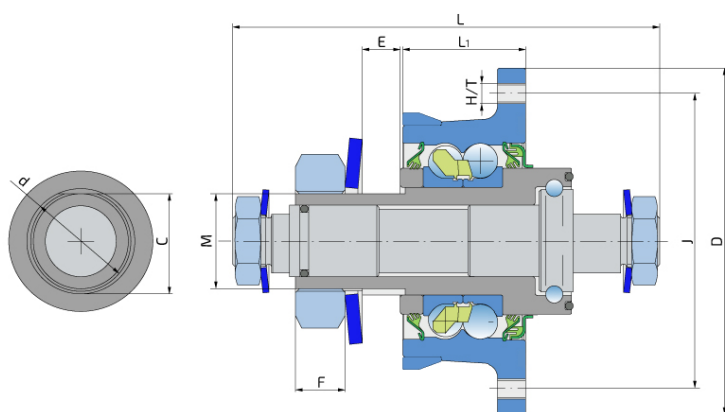

### Technical Specification

J	Pitch circle diameter	115 mm
D	Outside diameter	135 mm
H/T	Hole/Thread	6xM8 mm
d	Bore diameter	42 mm
C	D-shape hole cut out dimension	39.5 mm
M	Outer Thread	M39x1.5 mm
F	Length of threaded part	26 mm
L	Total length	167 mm
L1	Total flange length	48 mm
E	Length of D shape	15 mm
kg	Mass	4.214 kg
Cdyn	Dynamic load rating	66.35 kN
Co	Static load rating	56.49 kN
Pu	Fatigue load limit	2.37 kN

## Sealing

---

### DOUBLE T SEAL / T SEAL

3-lip seal on the base side and double 3-lip seal on the front side which is exposed to contaminants.

The double 3-lip seal on the front side protects the bearing from contaminant penetration. Also, the outer seal with 3 lips, with additional sealing, protects the inner seal from mechanical damage

&nbsp;

