

Integrated Flange, Maintenance-Free Bearing For Independent Discs

IL50-98/6T-B30-J

Integrated Flange, Maintenance-Free Bearing For Independent Discs
Disc Harrow

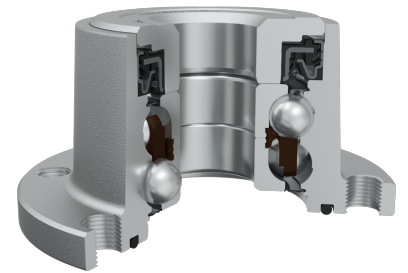
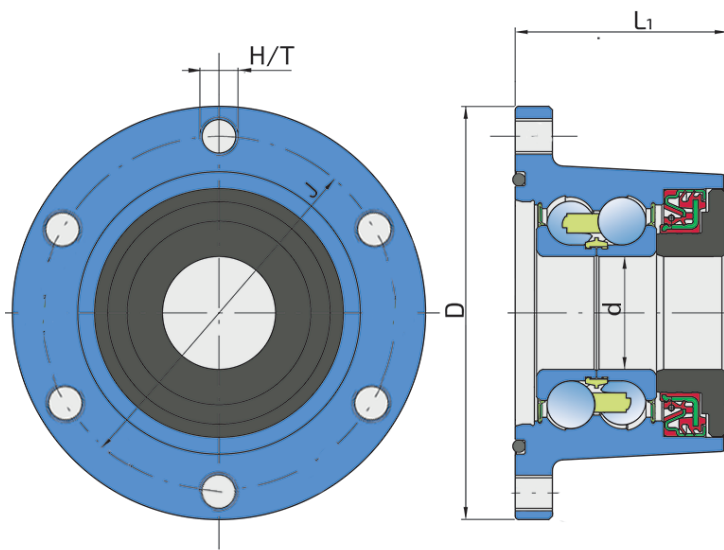

Technical Specification

J	Pitch circle diameter	98 mm
D	Outside diameter	117 mm
H/T	Hole/Thread	6xM12x1.25 mm
d1	Bore diameter	30 mm
L1	Total flange length	60 mm
kg	Mass	1.96 kg
Cdyn	Dynamic load rating	60 kN
Co	Static load rating	45.8 kN
Pu	Fatigue load limit	1.92 kN

Sealing

O-RING+RS SEAL / RS SEAL+DIRTBLOCK SEAL+FORGED COVER PLATE

O-ring and RS seal on the base side and RS seal, Dirtblock seal and Forged cover plate on the front side which is exposed to contaminants.

O-ring and RS seal together with attached special disc eliminates the possibility of contamination from the base side.

Dirtblock seal is designed for hard working conditions at unfriendly environment. Half metal - half rubber outside diameter provides reliable seal retention in the bore and improves sealing performance. Inside diameter is covered by rubber and improves sealing performance and easy installation. Forged cover plate is additional, strong protection of the Dirtblock seal against mechanical damage.

This sealing provides maximum protection against liquid or solid contaminants, which significantly extends bearing service life.

