

TEST REPORT

Mud Slurry Testing of AGRO POINT HUB: IL50-98/4T-M22

1. Testing Requirement

Durability of Hub bearings in operation submerged in mud slurry.

2. Testing Procedure

- Dynamic Load rating of IL50-98/4T-M22 : 60 kN
- Measured axial clearance before testing= 0.014mm

2.1 Mud Slurry Testing under load:

- Radial Force $F_r=3.5$ kN
- Axial Force $F_a=3.5$ kN
- Test speed $n=245$ rpm

2.2 Test Rig

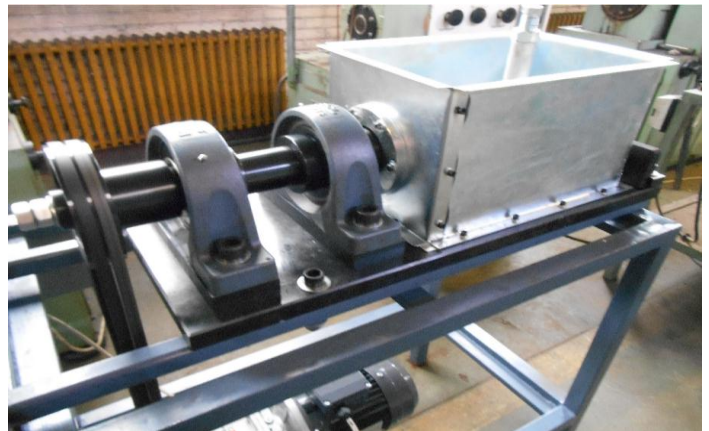
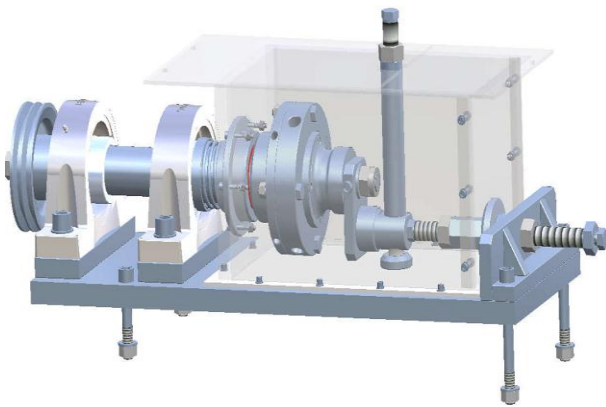

2.3 Loading procedure:

1. When the Test Rig is off, tighten the radial load bolt to the specified torque, using the Torque Wrench.
2. When the Test Rig is off, tighten the axial load bolt to the specified torque, using the Torque Wrench.
3. Turn on the Test Rig.
4. As the hub rotates, complete the tightening of the bolts for both load directions, first radially, to the specified torque of -12Nm using a torque wrench.



Radial Load

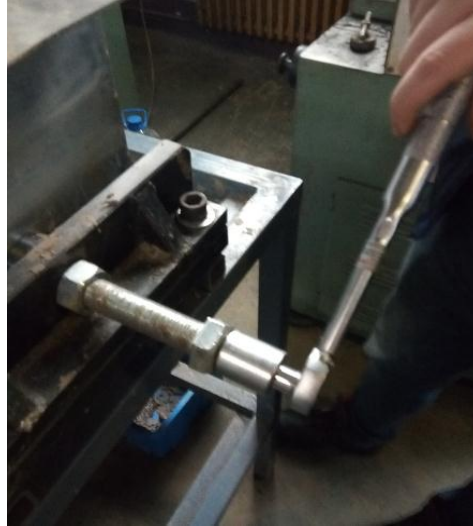

Axial Load

2.4 Torque Wrench:

- Torque range 10-50Nm,
- Adjustable in 0.5Nm steps.



2.5 Content of Mud Slurry:

- 6 kg of Soil dust,
- 2 kg of Sand,
- 50g of Phosphate fertilizer,
- 7 liter of Water.

2.6 Criteria to stop testing:

- 1000 hours operation with no signals of damage. The bearing must remain fully operational.
- Significant increase in the internal clearance of the Hub bearing. What is the bearing damage signal.

3. Test Results





After 1134 hours the testing was stopped due to the increase in bearing vibrations.

- The bearing was disassembled and after analysis it was found that contaminants had penetrated through the cassette seal and caused the damage on the inner ring near to the cassette seal.
- The lubricant on that side of the bearing is contaminated with many particles. The other side of the bearing is mostly clean.
- Measured axial clearance after testing= 0.3mm.

Calculated on the area of the field, the duration of 1134 hours is 250.000 hectares.

Testing engineer

Laslo Koman dipl.ing.

Head of Laboratory

Milivoje Mijušković dipl.ing.